

R3C FEMALE COAX CAB 5/75

PACKAGING REEL 2400

R299.197.260

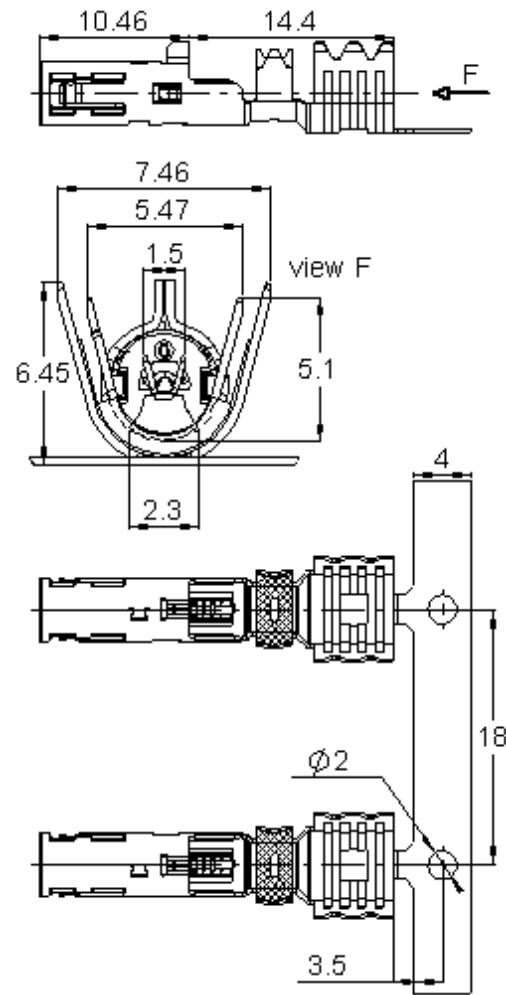
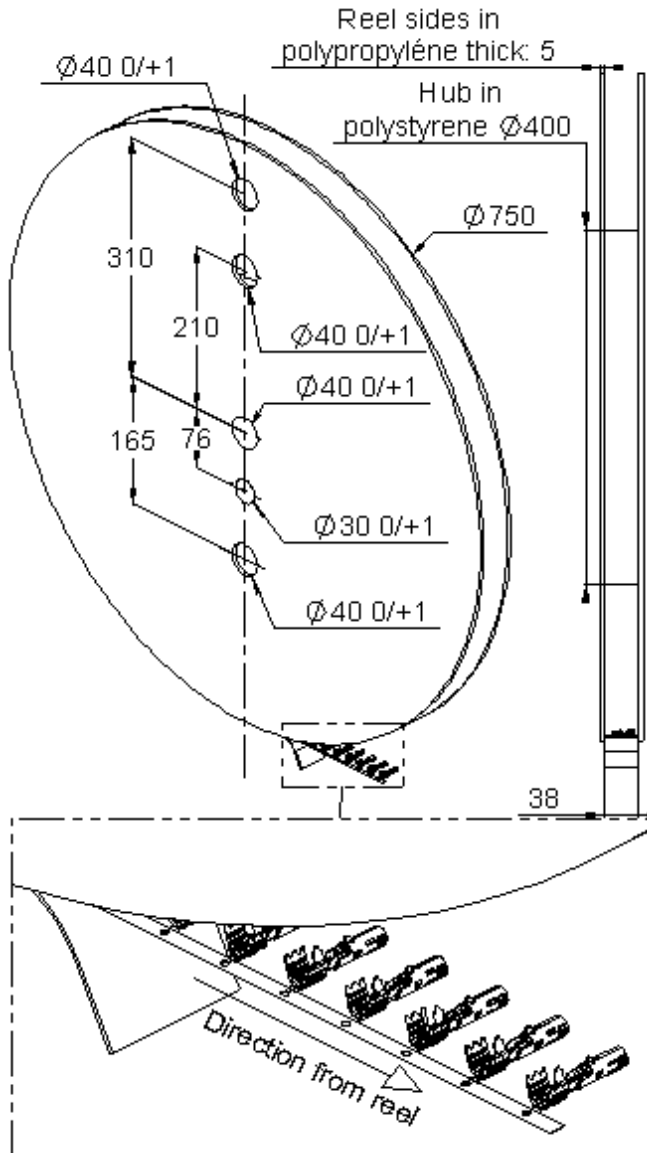

THIS COAX CAN BE USED WITH HOUSING R197.115_81 (replaced the _ by the coding letter)

All dimensions are in mm.

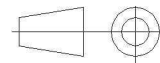

COMPONENTS	MATERIALS	PLATING (µm)	
BODY	BRONZE	TIN 3 OVER NICKEL 2	
CENTER CONTACT	BRONZE	SELECTIVE GOLD+ SELECTIVE TIN	
OUTER CONTACT	-	-	
INSULATOR	POLYMER	UL CLASSIFICATION	COLOR
	-	UL94-V0	NATURAL
	-		

Standard Packaging : 2400+/-2%*

* Nota : possibility of having a maximum of five missing parts consecutively on the tape

Issue : 0748 B

In the effort to improve our products, we reserve the right to make changes judged to be necessary.



R3C FEMALE COAX CAB 5/75

PACKAGING REEL 2400

R299.197.260

Recommended Stripping dimensions of the 5/75Ω cable for R3C female R299.197.260

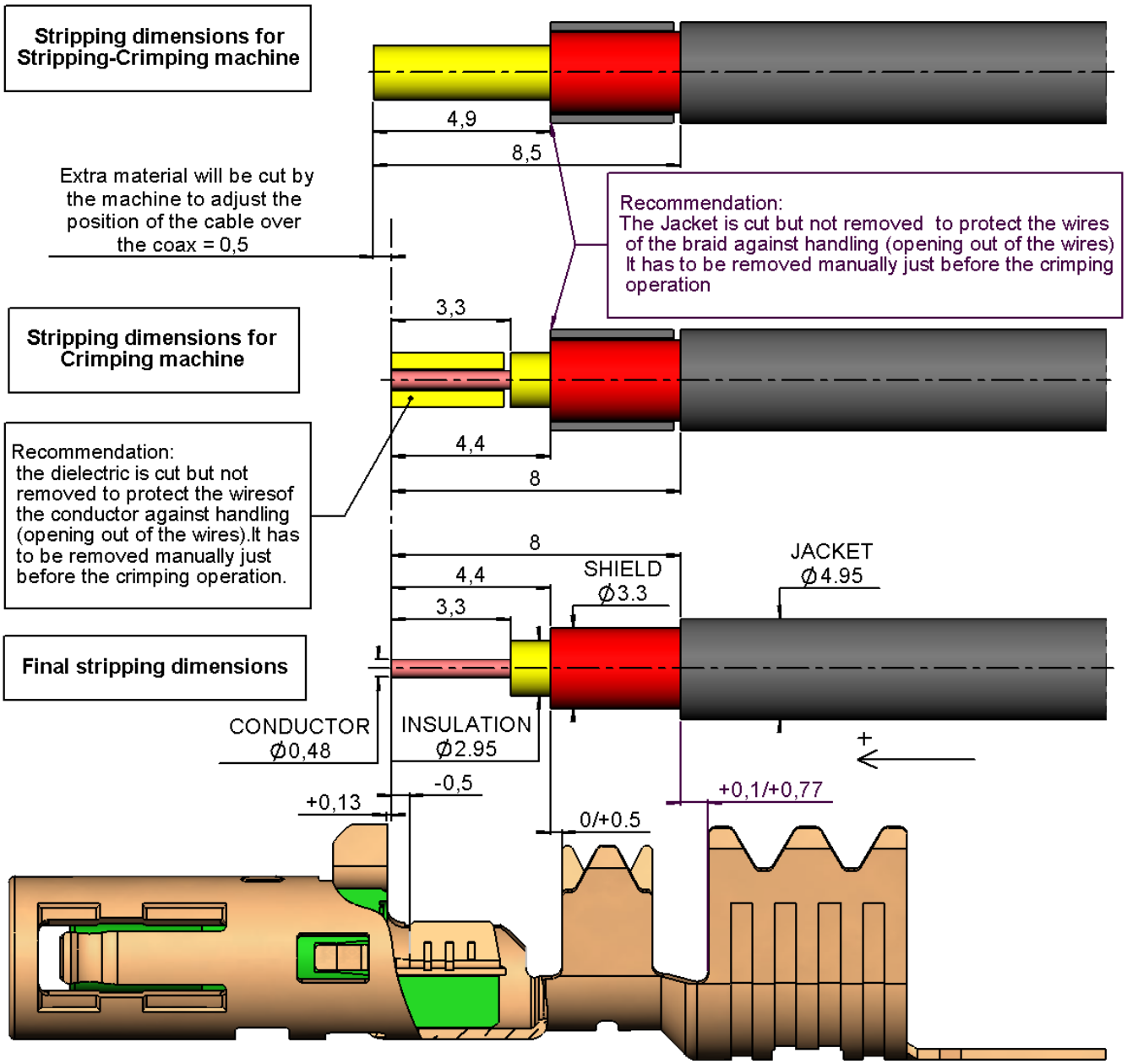

PATENTED

Issue : 0748 B
 In the effort to improve our products, we reserve the right to make changes judged to be necessary.



R3C FEMALE COAX CAB 5/75

PACKAGING REEL 2400

R299.197.260

crimping height **			
conductor X	braid Y	jacket Z	conductor/body W
0,79±0,05	3,55±0,05	4,8+0,05/-0,1	2,47±0,07

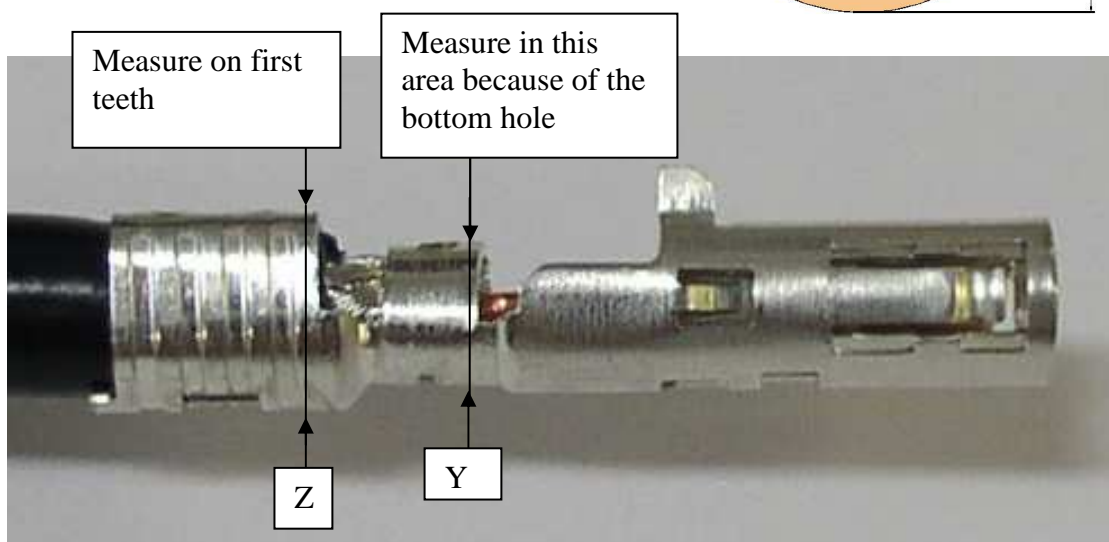
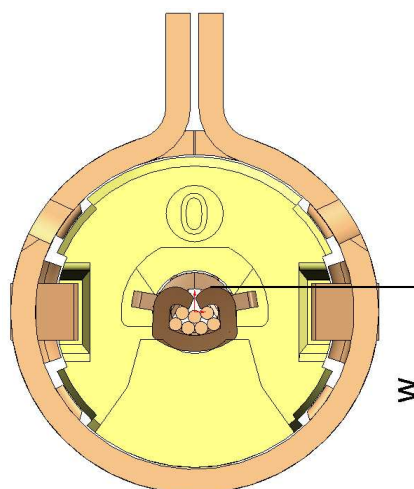
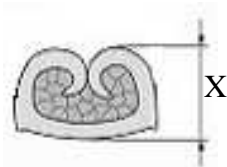

**** CAUTION**

- Before using applicator, make sure the press is calibrated :135,8 mm from the lower dead point up to the base
- Crimping height may change depending on the manufacturer of the cable, for more informations please contact us
- We recommend to make electrical test after each set up of the applicator:
 - Outer and center contact continuity+Dielectric withstanding voltage 800Vrms, 50Hz
 - Insulation resistance 1000 Mohms
 - Cable retention = 110Newton mini during 5 seconds with electrical continuity

Issue : 0748 B

In the effort to improve our products, we reserve the right to make changes judged to be necessary.

